

STORA SUPER 200 - H300

with F900 slotted ductile iron gratings, 10mm slot



EN1433:2005

F900



DESCRIPTION

Polyester concrete drainage channel with cast iron protective edge profile, width 200, height 300 and 2 gratings F900 ductile iron, 10mm slot. Solid construction, good chemical resistance, integrated ductile iron profile, with security joint.

ADVANTAGE PRODUCT

- Grating: 2 gratings ductile iron, 10mm slot
- Waterway area of the 2 gratings: 8,60 dm²
- Hydraulic capacity of the 2 gratings: 56,50 L/sec
- Opening between bars <20mm. To guarantee the accessibility of public places for disabled persons, the slots of the gratings with the disabled-symbol are never larger than 20mm.
- Gratings with unique anti-skid surface
- Predrilled vertical outlet Ø200mm
- Grating fixing system: 1 M10 stainless steel bolt per grating + 2 integrated, in the profile, ridges
- The channels are assembled against each other by means of a tongue and groove jointing system (male/female); to ensure the channels watertightness it is recommended to use a suitable elastic polyurethane sealant.
- Cascade installation possible in combination with heights 180 and 240.

MATERIAL

- Channel: polyester concrete
- Protective edge profile: ductile iron GJS 500-7 following EN1563
- Grating: ductile iron GJS 500-7 following EN1563

COATING

Grating: Non-toxic and non-polluting black water paint

CERTIFICATION

Certified EN1433:2005

PLACE OF INSTALLATION

Group 6, Class F900 →see EN1433:2005

Areas subjected to especially high wheel loads (e.g. aircraft pavements). Only longitudinal use, never transverse direction.

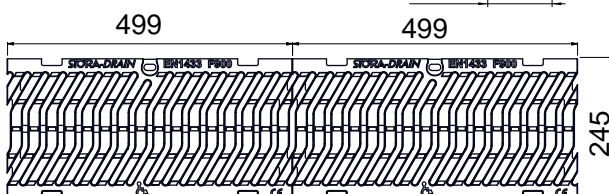
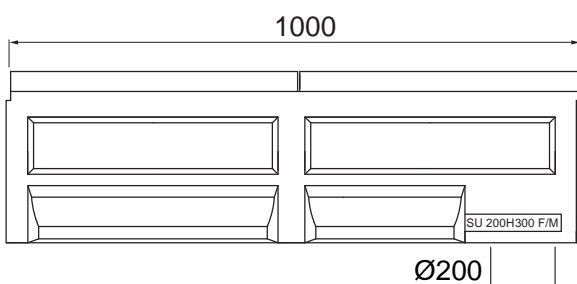
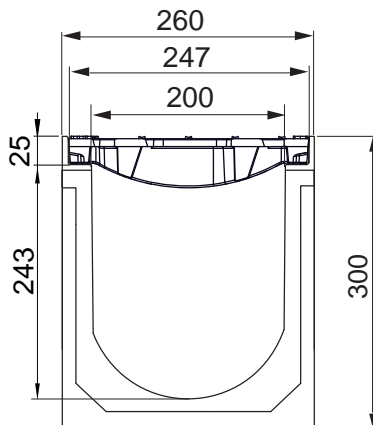

OPTIONS

- Universal endcap with integrated outlet Ø160
- Sump unit
- Stepped fall
- Also available in heights 130, 180 and 240
- Available in 0.5m length with outlet 390x130

REFERENCE	ARTICLE N°	KG	UNITS PER PALLET
Stora-Super 200 H300 slotted gratings F900 ductile iron, 10mm slot.	SU20301325	77,5	12

Sizes in mm - Weights, sizes and sketch are indicative - Uncontrolled distribution.