

# STORA SUPER 150 - H220

## with F900 slotted ductile iron gratings, 10mm slot

EN1433:2005

F900



### DESCRIPTION

Polyester concrete drainage channel with cast iron protective edge profile, width 150, height 220 and 2 gratings F900 ductile iron, 10mm slot. Solid construction, good chemical resistance, integrated ductile iron profile, with security joint.

### ADVANTAGE PRODUCT

- Grating: 2 gratings ductile iron, 10mm slot
- Waterway area of the 2 gratings: 6,00 dm<sup>2</sup>
- Hydraulic capacity of the 2 gratings: 39,40 L/sec
- Opening between bars <20mm. To guarantee the accessibility of public places for disabled persons, the slots of the gratings with the disabled-symbol are never larger than 20mm.
- Gratings with unique anti-skid surface
- Predrilled vertical outlet Ø160mm
- Grating fixing system: 1 M10 stainless steel bolt per grating + 2 integrated, in the profile, ridges
- The channels are assembled against each other by means of a tongue and groove jointing system (male/female); to ensure the channels watertightness it is recommended to use a suitable elastic polyurethane sealant.
- Cascade installation possible in combination with heights 170 and 270

### MATERIAL

- Channel: polyester concrete
- Protective edge profile: ductile iron GJS 500-7 following EN1563
- Grating: ductile iron GJS 500-7 following EN1563

### COATING

Grating: Non-toxic and non-polluting black water paint

### CERTIFICATION

Certified EN1433:2005

### PLACE OF INSTALLATION

Group 6, Class F900 →see EN1433:2005

Areas subjected to especially high wheel loads (e.g. aircraft pavements). Only longitudinal use, never transverse direction.

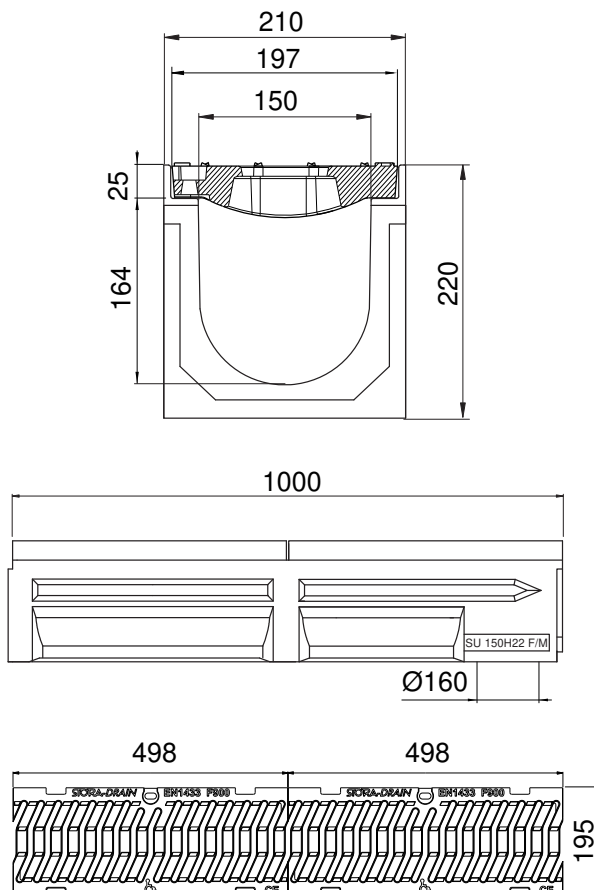

### OPTIONS

- Universal endcap with integrated outlet Ø110
- Sump unit
- Stepped fall
- Also available in heights 170 and 270

REFERENCE	ARTICLE N°	KG	UNITS PER PALLET
Stora-Super 150 H220 slotted gratings F900 ductile iron, 10mm slot.	SU15221328	58,70	24

Sizes in mm - Weights, sizes and sketch are indicative - Uncontrolled distribution.