

STORA SELF 100 - H100

with slotted galvanised grating A15, 10mm slot

EN1433:2005

A15

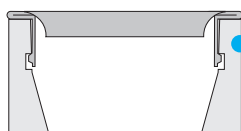
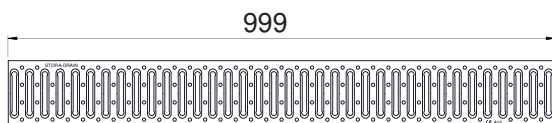
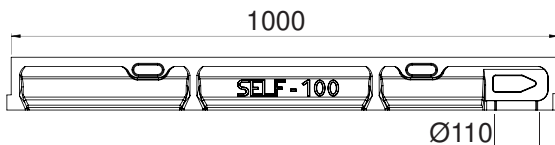
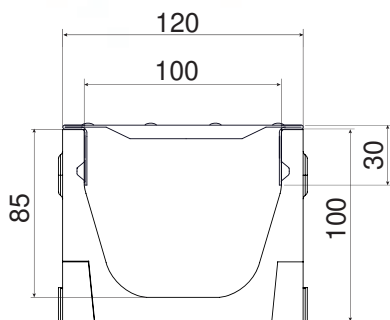

Fix system

DESCRIPTION

Polyester concrete drainage channel, width 100, height 100 and slotted galvanised steel grating A15, 10mm slot.

PRODUCT ADVANTAGES

- Grating: slotted galvanised steel grating, 10mm slot
- Waterway area of the grating: 2,80dm²
- Hydraulic capacity of the grating: 18,39 L/sec
- Grating slot < 20 mm, for additional security for wheelchairs and bicycles.
- Grating fixing system: Fix system
- Predrilled vertical outlet Ø110
- Release through leverage by any traditional tools
- Edges of the channels are not visible = aesthetic
- The channels are assembled against each other by means of a tongue and groove jointing system (male/female); to ensure the channels watertightness it is recommended to use a suitable elastic polyurethane sealant.

MATERIAL

- Channel: polyester concrete
- Grating: galvanised steel

CERTIFICATION

Certified EN 1433:2005

PLACE OF INSTALLATION

Group 1, Class A15 →see EN1433

Around private houses: on terraces, in front of garage doors and on domestic driveways.

OPTIONS

- Endcap with outlet Ø 110
- Endcap without outlet
- Sump unit
- Stepped fall
- Also available in height 60 and 80

REFERENCE	ARTICLE N°	KG	UNITS PER PALLET
Stora-Self 100 H100 slotted galvanised grating, 10mm slot A15	SE10101100SN	7,90	108
Stora-Self 100 H100 channel 1m with outlet	SE10101000N	6,30	
Slotted galvanised grating, 10mm slot A15	RSE100A100	1,60	

Sizes in mm - Weights, sizes and sketch are indicative - Uncontrolled distribution.