

## STORA OPTIMA PLUS 100 - H150

with D400 slotted ductile iron gratings, "WAVE"

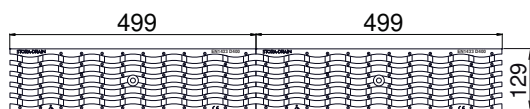
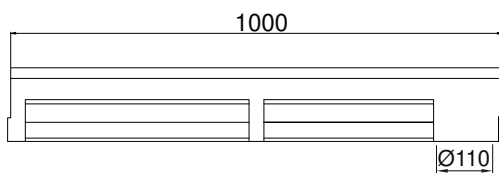
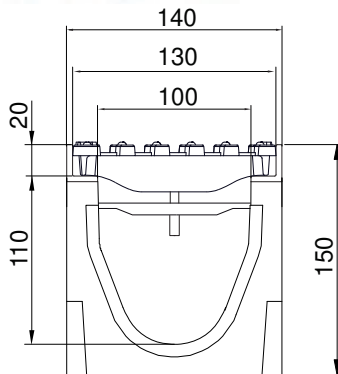

### OPTIONS

- Sump unit
- Stepped fall
- Endcap with Ø 110 outlet
- Endcap without outlet
- Also available in height 200 and 250
- Channel 0,5m cross piece with vertical outlet Ø 110

EN1433:2005

D400



### DESCRIPTION

Polyester concrete drainage channel, width 100, height 150 with protective iron profile and slotted ductile iron gratings D400, "WAVE" 12mm slot.

### PRODUCT ADVANTAGES

- Grating: 2 slotted gratings ductile iron, "WAVE" 12mm slot
- Waterway area of the 2 gratings: 1,80 dm<sup>2</sup>
- Hydraulic capacity of the 2 gratings: 11,83 L/sec
- Drainage channel with protective iron profile
- Grating slot < 20 mm, for additional security for wheelchairs and bicycles.
- Predrilled vertical outlet Ø110
- Grating fixing system: anchorage type I
- The channels are assembled against each other by means of a tongue and groove jointing system (male/female); to ensure the channels watertightness it is recommended to use a suitable elastic polyurethane sealant.
- Can be installed in cascade with height 200 and 250.

### MATERIAL

- Channel: polyester concrete
- Channel profile: ductile iron GJS 500-7 following on EN1563
- Grating: ductile iron GJS 500-7 following on EN1563

### COATING

Grating: Non-toxic and non-polluting black water paint

### CERTIFICATION

Certified EN 1433:2005

### PLACE OF INSTALLATION

Group 4, Class D400 → see EN1433:2005

Load traffic lanes (including pedestrian streets), hard shoulders and parking areas, for all types of road vehicles. Only longitudinal use, never transverse direction.

REFERENCE	ARTICLE N°	KG	UNITS PER PALLET
STORA-OPTIMA PLUS 100 H150 ductile iron gratings D400	SOP10151356	23,60	35
STORA-OPTIMA PLUS 100 H150 channel 1m	SOP10151000		
Ductile iron gratings D400, "WAVE" 12mm slot	RSB100D356		-
Anchorage type I	S5100001	-	-

Sizes in mm - Weights, sizes and sketch are indicative - Uncontrolled distribution.