

STORA LIGHT 100 - H110

with slotted galvanised grating A15, 6mm slot

A15



DESCRIPTION

Polypropylene drainage channel width 100, height 110 with slotted galvanised grating A15, 6mm slot.

PRODUCT ADVANTAGES

- Lightweight channel, made of polypropylene.
- Waterway area of the grating: 1,42 dm²
- Hydraulic capacity of the grating: 9,33 L/sec
- The channel was designed to be used around private houses.
- Grating slot < 20 mm, for additional security for wheelchairs and bicycles.
- Pre-formed / to be cut out vertical outlet Ø100mm
- The channels are assembled against each other by means of a tongue and groove jointing system (male/female); to ensure the channels watertightness it is recommended to use a suitable elastic polyurethane sealant.
- Easy, 100% recyclable = environment friendly
- Easy opening by means of any traditional tool, (e.g. screwdriver).

MATERIAL

- Channel: polypropylene
- Grating: galvanised steel

PLACE OF INSTALLATION

Group 1, Class A15 → see EN1433

Around private houses: on terraces and on domestic driveways.

OPTIONS

- Sealant for the watertightness of connections
- Grating fixing with anchor and screws
- Endcap with preformed outlet
- Connection pipe Ø110mm
- Siphon 100

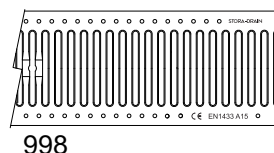
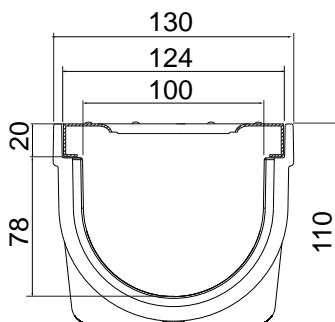

REFERENCE	ARTICLE N°	KG	UNITS PER PALLET
Stora-Light 100 H110 slotted galvanised grating A15, 6mm slot	S6500430	2,80	72
Stora-Light 100 H110 channel 1m	S6500400X	1,40	
Slotted galvanised grating A15	S2400010	1,40	

Sizes in mm - Weights, sizes and sketch are indicative - Uncontrolled distribution.