

STORA ELLIPSE 150 - H185

with ductile iron gratings B125, 10mm slot

B125

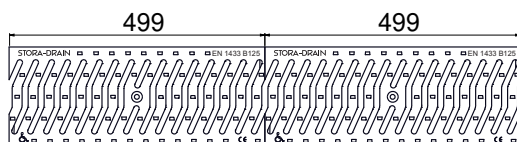
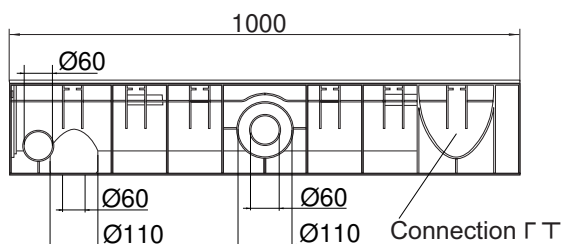
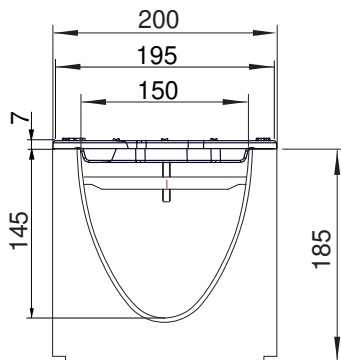

DESCRIPTION

Polypropylene drainage channel width 150, height 185 with ductile iron gratings B125, 10mm slot

PRODUCT ADVANTAGES

- Grating: 2 gratings ductile iron, 10mm slot
- Waterway area of the 2 gratings: 6,40 dm²
- Hydraulic capacity of the 2 gratings: 42,00 L/sec
- Grating slot < 20 mm, for additional security for wheelchairs and bicycles.
- Gratings with unique anti-skid surface
- Pre-formed / to be cut out vertical outlet Ø60 / Ø110
- Pre-formed / to be cut out side outlet Ø60 / Ø110
- Side connection Γ T
- Grating fixing system: anchorage screw
- Easy opening by means of any traditional tool
- The channels are assembled against each other by means of a tongue and groove jointing system (male/female); to ensure the channels watertightness it is recommended to use a suitable elastic polyurethane sealant.

MATERIAL

- Channel: polypropylene
- Grating: ductile iron GJS 500-7 following on EN1563

COATING

Grating: Non-toxic and non-polluting black water paint

PLACE OF INSTALLATION

Group 2, Class B125 →see EN1433

Footways, pedestrian areas and comparable areas, private car parks or car parking decks.

REFERENCE	ARTICLE N°	KG	UNITS PER PALLET
Stora-Ellipse 150 H185 ductile iron gratings B125, 10mm slot	S6100160	14,30	30
Stora-Ellipse 150 H185 channel 1m	S6100150	3,70	
Ductile iron gratings B125, 10mm slot		(2x) 5,30	
Anchorage type I	S5100001		

Sizes in mm - Weights, sizes and sketch are indicative - Uncontrolled distribution.