

# STORA BASE 150 - H120

## with C250 slotted ductile iron gratings, "WAVE"

EN1433:2005

C250



### DESCRIPTION

Polyester concrete drainage channel, width 150, height 120 with slotted ductile iron gratings C250, "WAVE" 12mm slot. Drainage channels for car parks, shopping streets and pavements

### PRODUCT ADVANTAGES

- Grating: 2 slotted gratings ductile iron, "WAVE" 12mm slot
- Waterway area of the 2 gratings: 3,10 dm<sup>2</sup>
- Hydraulic capacity of the 2 gratings: 20,40 L/sec
- Drainage channel with 2mm galvanized profile
- Grating slot < 20 mm, for additional security for wheelchairs and bicycles.
- Predrilled vertical outlet Ø160
- Grating fixing system: anchorage type I
- Release through leverage by any traditional tools
- The channels are assembled against each other by means of a tongue and groove jointing system (male/female); to ensure the channels watertightness it is recommended to use a suitable elastic polyurethane sealant.

### MATERIAL

- Channel: polyester concrete
- Channel profile: galvanised steel
- Grating: ductile iron GJS 500-7 following on EN1563

### COATING

Grating: Non-toxic and non-polluting black water paint

### CERTIFICATION

Certified EN 1433:2005

### PLACE OF INSTALLATION

Group 3, Class C250 →see EN1433

Kerb sides and non-trafficked areas of hard shoulders and similar.

### OPTIONS

- Endcap without outlet
- Also available in height 195 and 245
- Standard 0,5m channel with vertical outlet Ø160

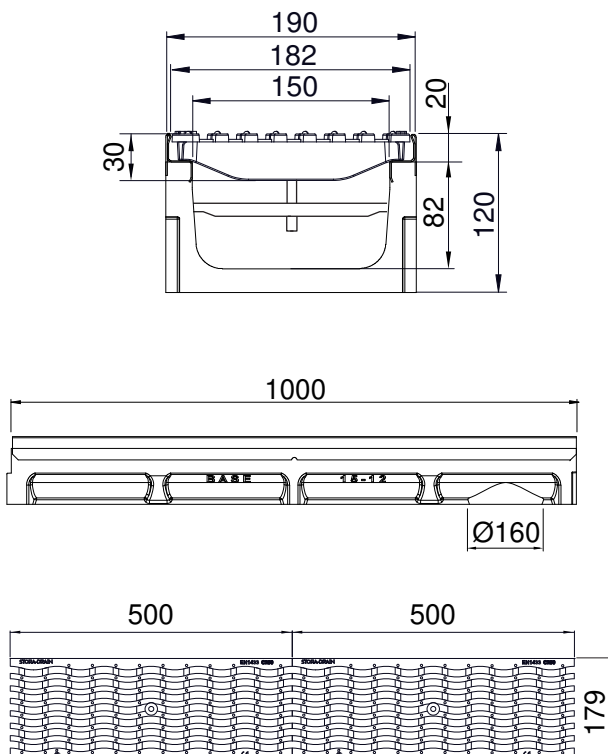

REFERENCE	ARTICLE N°	KG	UNITS PER PALLET
Stora-Base 150 H120 ductile iron „WAVE” gratings C250	SB15121353	22,90	
Stora-Base 150 H120 channel 1m	SB15121000	12,60	
Slotted ductile iron gratings C250, "WAVE" 12mm slot	RSB150C353	2x5,15	
Anchorage type I			

Sizes in mm - Weights, sizes and sketch are indicative - Uncontrolled distribution.